



GENUINE PARTS

INSTALLATION INSTRUCTIONS

| | |
|---------------------|----------------------------------|
| DESCRIPTION: | Rear Spoiler - Sport |
| APPLICATION: | Maxima |
| PART NUMBER: | T99J1 4RAxB (x designates color) |

KIT CONTENTS:

| Item | Qty. | Part Description | Service Part Number |
|------|------|---|---------------------|
| A | 1 | Spoiler Assembly | T99J1 4RAxB |
| B | 4 | M6 Nuts | 12-21 N6011 |
| C | 2 | Plastic Clips | N/A |
| D | 1 | Bar-Trunk Lid Torsion RH | 84432 4RA0C |
| E | 1 | Bar-Trunk Lid Torsion LH | 84433 4RA0C |
| F | 1 | Weatherstrip-Trunk Lid | 84830 4RA1B |
| G | 1 | Drill Template | N/A |
| H | 1 | Installation Instruction Replacement Template | 999V2 AW000 |

TOOLS REQUIRED:

- Clean shop rags
- Flathead screw driver
- Masking tape
- Drop cloth
- Vacuum
- Microfiber cloth
- Safety goggles
- Hammer
- Center punch
- Tape measure
- Deburring tool
- Variable speed drill
- Drill bits: 1/8" or 3mm, 9/32" or 7mm, 11/32" or 9mm, 9/16" or 14mm
- Torque wrench
- Ratchet with extension
- 10mm deep socket
- Rust preventative (P/N 999MP-9G001P)
- Alcohol solution 90% or greater

PRE-INSTALLATION WARNINGS, CAUTIONS, CRITICAL STEPS, and NOTES:

- Some plastic surfaces may become damaged by alcohol solution. Cover and protect taillight lenses. If alcohol does come into contact with the lens, immediately wash surface with water.
- Failure to clean mounting surface properly may cause tape to have poor adhesion to vehicle.
- If vehicle has been recently painted, allow paint to dry and age 24 hours before installing spoiler.
- Install spoiler when ambient temperature is above 15°C (60° F).
- Do not wash or expose vehicle to a wet environment for 24 hrs. after installing spoiler.

WARNING

- Dealer Installation required for torsion bar replacement. Torsion bars under high tension and spring back can occur during installation and removal. Special tool is required.

INSTALLATION PROCEDURE:

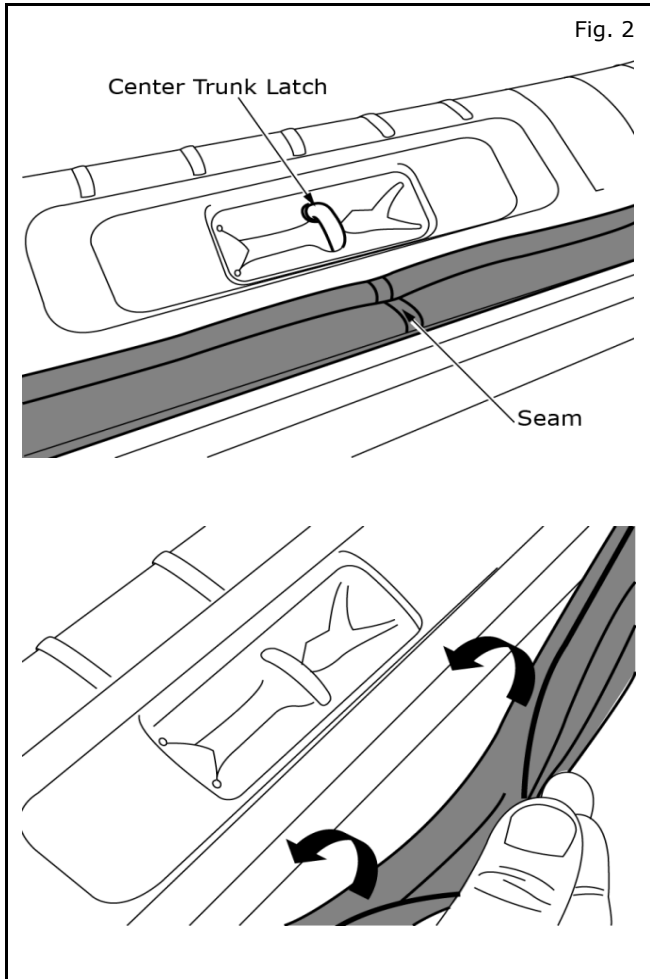
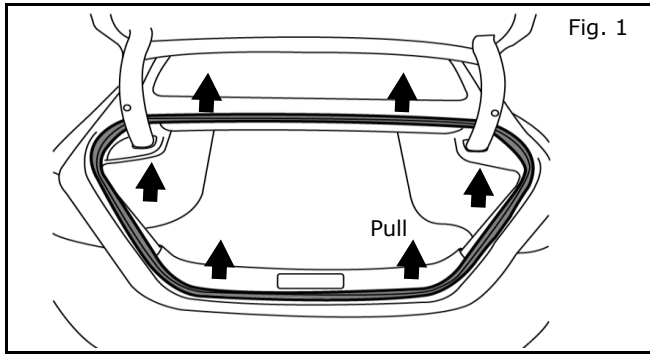

1) Trunk lid seal replacement.

a) Remove trunk lid seal by pulling up on seal as shown.

b) Locate seam on seal to center trunk latch.

c) Seal has two grooves. Use bottom (most rigid) groove.

d) Install new seal making sure to fully engage seal on vehicle.

INSTALLATION PROCEDURE:

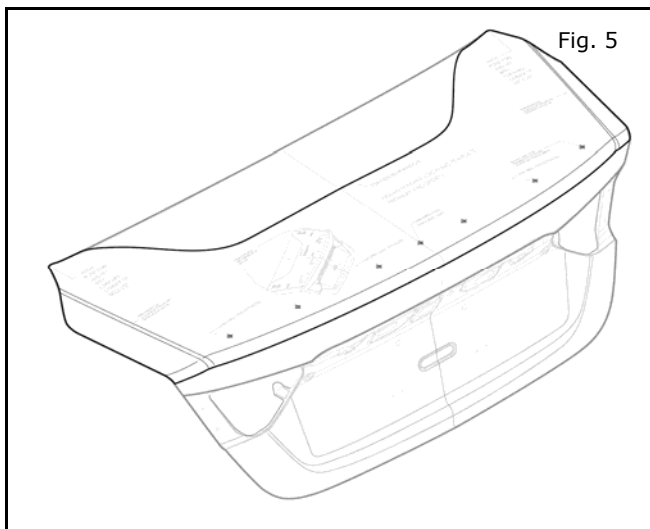
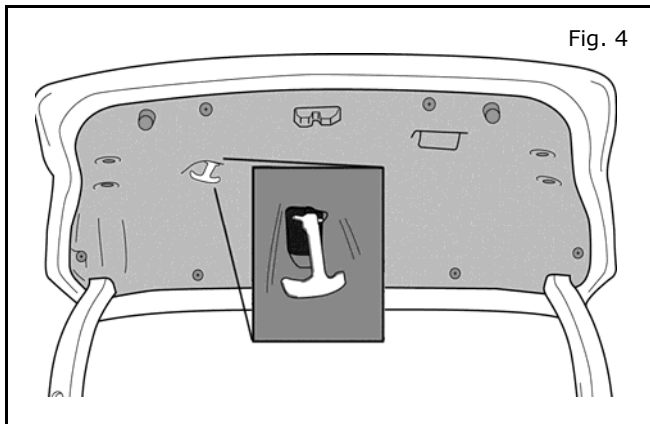
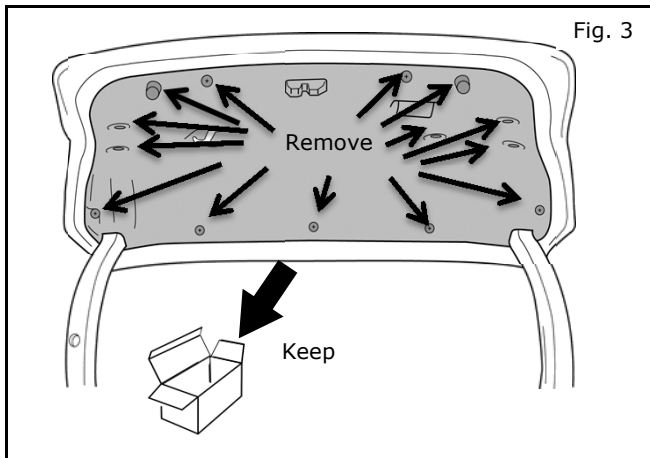

2) Inner liner removal (if equipped).

- a) Open trunk lid.
- b) Place a drop cloth in trunk to cover the inside.
- c) Remove (12) push pins and (2) bumpers and keep to re-use.
- d) Unhook emergency trunk release from black holder.
- e) Lift top edge of liner over latch. Slide inner liner down and out from behind emergency trunk release and remove liner.

3) Position drill template and drill holes.

- a) Use instructions on drill template to align on trunk lid.
- b) Tape template to trunk lid by tape marks on template in sequential order.

INSTALLATION PROCEDURE:

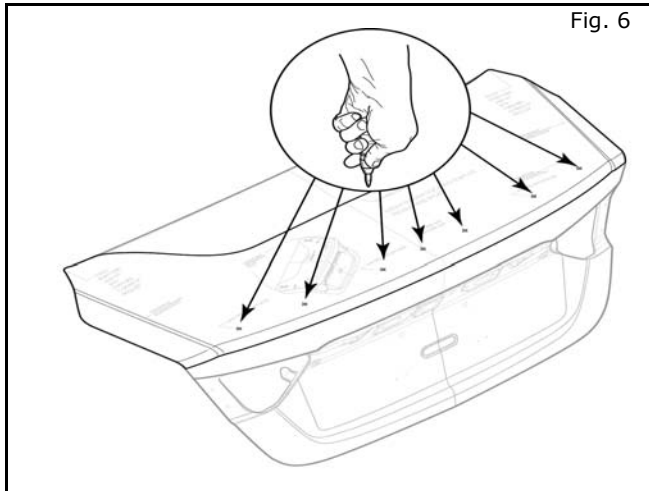

- c) Locate punch marks in center of printed hole locations. A light, quick impact on center punch is recommended to prevent a deep dent on trunk lid. Seven (7) places total.

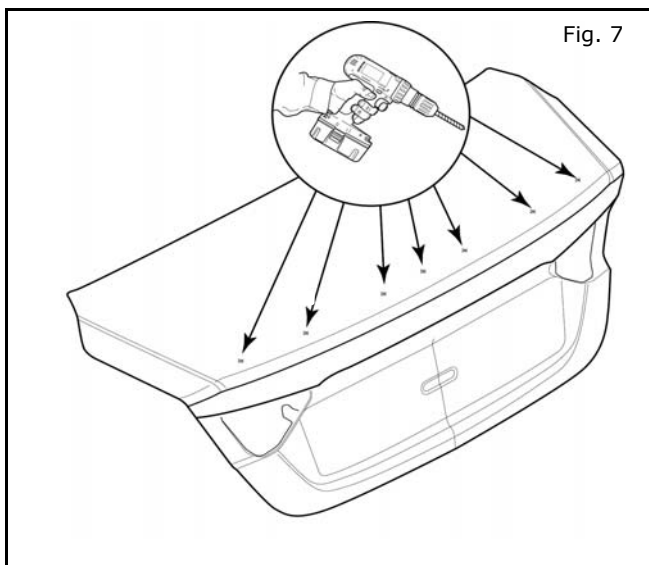

- d) Remove template and drill 3mm (1/8") pilot holes at seven (7) punch mark locations.
- e) Drill holes to final sizes as indicated on drill template.
- f) Use vacuum to remove sheet metal shavings from inside trunk area and installation area.

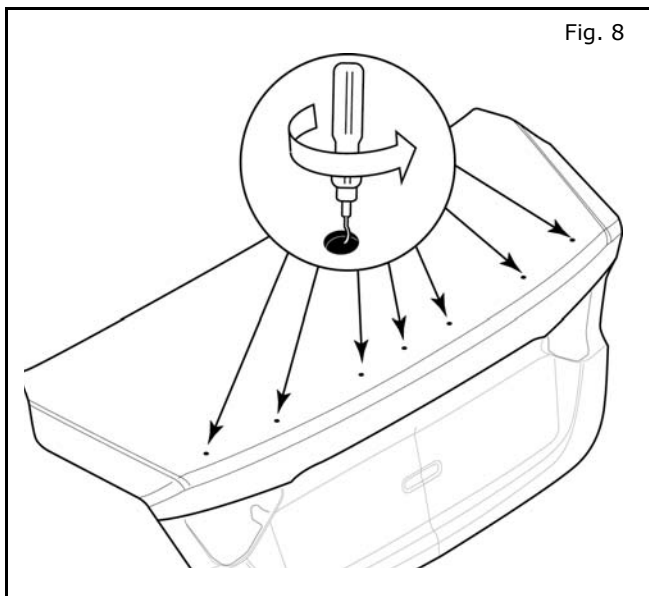

- g) De-burr seven holes and remove the metal chips from top and bottom of trunk lid.
- h) Apply rust preventative to drilled holes.

INSTALLATION PROCEDURE:

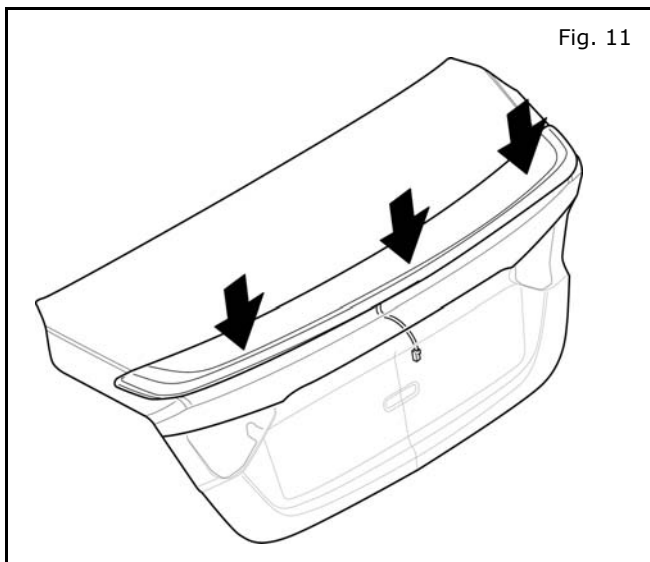
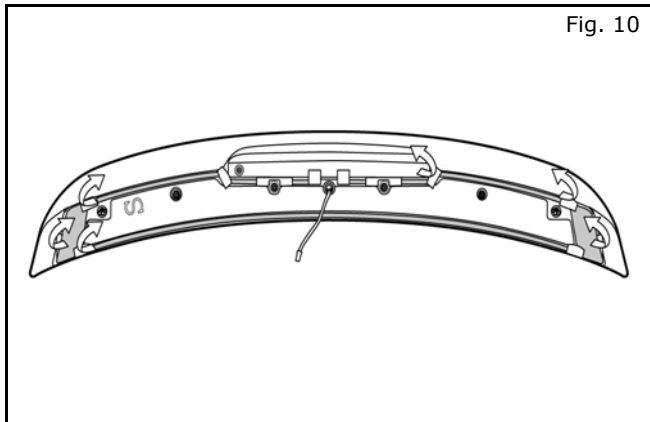
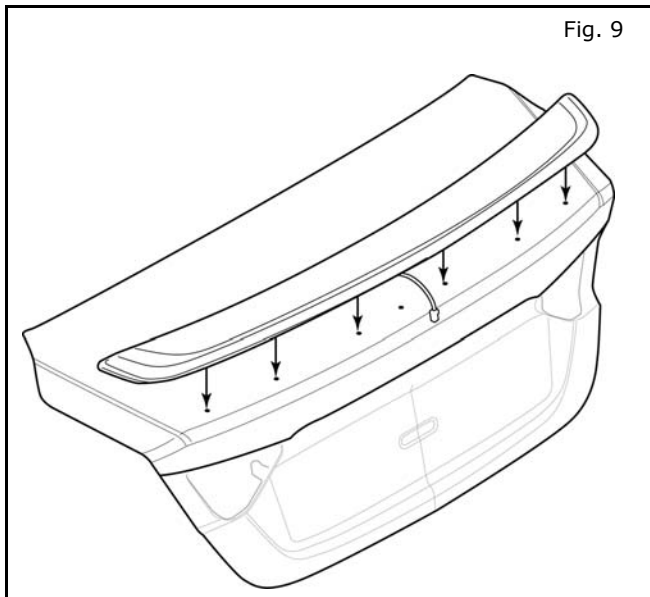

4) Attach rear spoiler to the trunk lid.

- a) Surface of trunk lid must be cleaned with alcohol solution of 90% or greater.
- b) Trunk temperature should be at least 60° F (15° C) for proper start-up adhesion of tape. Use a hot air blower if the temperature is below 60° F (15° C).
- c) Carefully place spoiler on trunk lid. Confirm gaps are equal on both sides of spoiler and check for proper hole alignment.

NOTE:

DO NOT ENGAGE CLIPS IN THIS STEP.

d) Remove spoiler.

e) Remove tape liners and insert lamp harness through 14mm hole.

f) Insert lamp harness through 14mm hole.

NOTE:

Grommet on harness must be sealed into trunk lid.

g) Carefully place the spoiler on trunk lid.

INSTALLATION PROCEDURE:

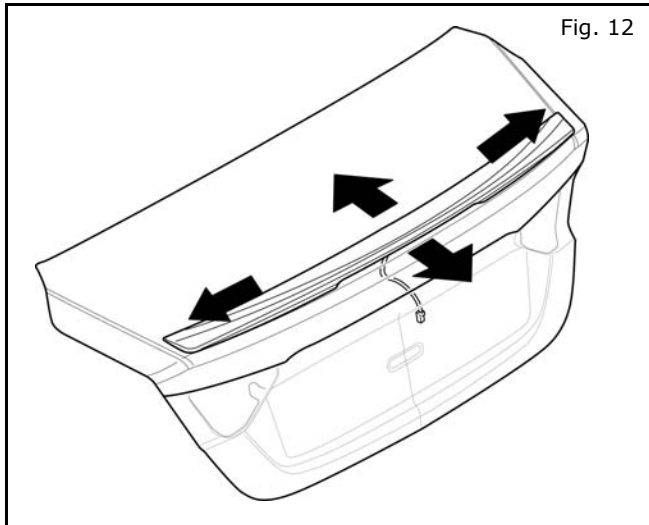

- h) If necessary adjust the (2) sliding plastic clips.
- i) Before contacting the tape to the trunk lid, verify that the spoiler is centered to the trunk lid.
- j) Starting from center using a micro fiber cloth apply 15lbs of pressure on spoiler to adhere tape to trunk lid.

NOTE:

Pressure must be applied around entire perimeter of spoilers.

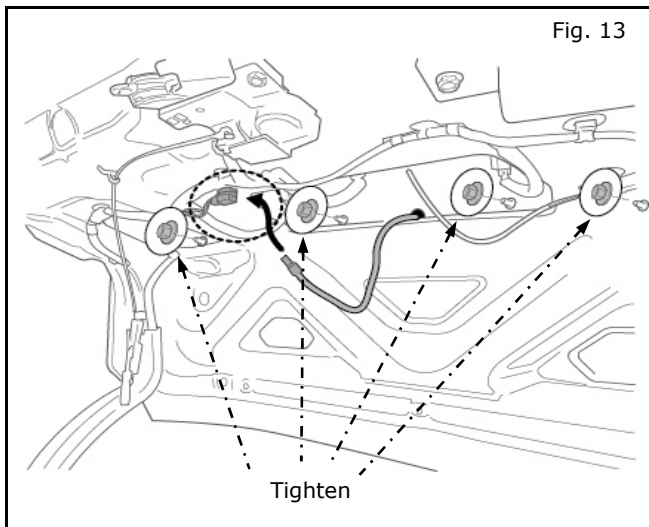

- k) Open trunk and install (4) M6 nuts onto studs with a 10mm socket tightened to 3.8 N-m.
- l) Pull lamp harness from inside of trunk compartment and confirm grommet seal is seated in hole.

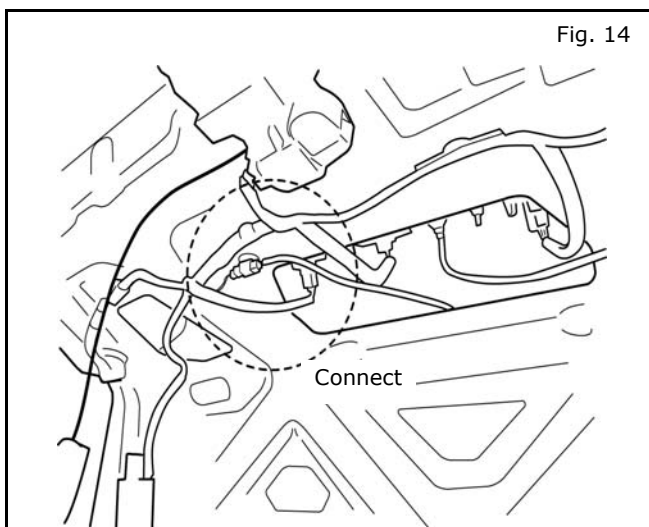

- 5) Connect HMSL and wiring harness.
 - a) Find brown connector near center hole (right of left side).
 - b) Connect spoiler HMSL harness connector to vehicle harness connector.
- 6) Confirm spoiler gap (0.5mm +0.7,-0.4).
- 7) Reinstall inner liner.
- 8) Take car to Nissan Dealer to have new torsion rods installed (parts included in kit).

NOTE:

Special tool required for torsion rod replacement.

INSTALLATION PROCEDURE:

ACCESSORY CHECK:

- Check all **torque** values. (Reference related steps and figures)
- Verify all wiring is secure and not exposed.
- Turn ignition switch to "**ON**" position.
- Confirm accessory main features and functions including all of its controls, opening and closing mechanism.
Verify that you can open the trunk with the emergency trunk release.